

<b>PLAN OF SUBDIVISION</b>		LRS USE ONLY	<b>PS 730190 V</b>	
<p style="text-align: center;"><b>LOCATION OF LAND</b></p> <p><b>PARISH :</b> PAKENHAM</p> <p><b>TOWNSHIP :</b> _____</p> <p><b>SECTION :</b> _____</p> <p><b>CROWN ALLOTMENT :</b> _____</p> <p><b>CROWN PORTION :</b> 31 (Pt)</p> <p><b>TITLE REFERENCE :</b> C/T. Vol. 9570 Fol. 265</p> <p><b>LAST PLAN REFERENCE :</b> LOT 1 ON TP 137331</p> <p><b>POSTAL ADDRESS :</b> No. 70 BRUNT ROAD, (At time of subdivision) BEACONSFIELD, 3807.</p> <p><b>MGA94 Co-ordinates :</b> (of approx. centre of land in plan) E 358 487 ZONE : 55 N 5786 035</p>		<p>Council Name: Cardinia Shire Council</p> <p>Council Reference Number: S16/058 Planning Permit Reference: T130340-1 SPEAR Reference Number: S082978B</p> <p>Certification</p> <p>This plan is certified under section 6 of the Subdivision Act 1988</p> <p>Public Open Space</p> <p>A requirement for public open space under section 18 of the Subdivision Act 1988 Has been made and the requirement has not been satisfied at Certification</p> <p>Digitally signed by: Dean Haeusler for Cardinia Shire Council on 03/03/2017</p>		
<b>VESTING OF ROADS AND/OR RESERVES</b>		<b>NOTATIONS</b>		
IDENTIFIER	COUNCIL/BODY/PERSON		<p><u>OTHER PURPOSE OF PLAN</u></p> <p>To create a Restriction (See Sheets 5 &amp; 6).</p>	
ROAD R-1	CARDINIA SHIRE COUNCIL			
<b>NOTATIONS</b>				
DEPTH LIMITATION : Does not apply.				
This is a SPEAR plan.				
Survey: This plan is based on survey.				
This survey has been connected to permanent marks no.(s) 20 & 535 in Proclaimed Survey Area No. 71				
STAGING: This is a staged subdivision Planning Permit No. T130340				
<b>EASEMENT INFORMATION</b>				
<b>LEGEND:</b> A - Appurtenant Easement      E - Encumbering Easement      R - Encumbering Easement (Road)				
Easement Reference	Purpose	Width (metres)	Origin	Land Benefited/In Favour Of
E-1	SEWERAGE	3	THIS PLAN	SOUTH EAST WATER CORPORATION & LOTS ON THIS PLAN.
	DRAINAGE	3	THIS PLAN	CARDINIA SHIRE COUNCIL & LOTS ON THIS PLAN
E-2	SEWERAGE	2	THIS PLAN	SOUTH EAST WATER CORPORATION & LOTS ON THIS PLAN.
<p><b>RODNEY AUJARD &amp; ASSOCIATES</b> <i>Licensed Land Surveyors</i></p> <p>Level 1, 325 Camberwell Road, CAMBERWELL. 3124. Ph. 9813 2222 Fax. 9813 2244</p> <p>aujard@bigpond.net.au</p>		<p>Surveyors Ref. 17965</p> <p>Digitally signed by: Geoff Peter Sutherland (Rodney Aujard and Associates), Surveyor's Plan Version (10), 24/01/2017</p>		<p>Original Sheet Size : A3</p> <p>SHEET 1 OF 6</p>

M.G.A. - 94  
ZONE 55

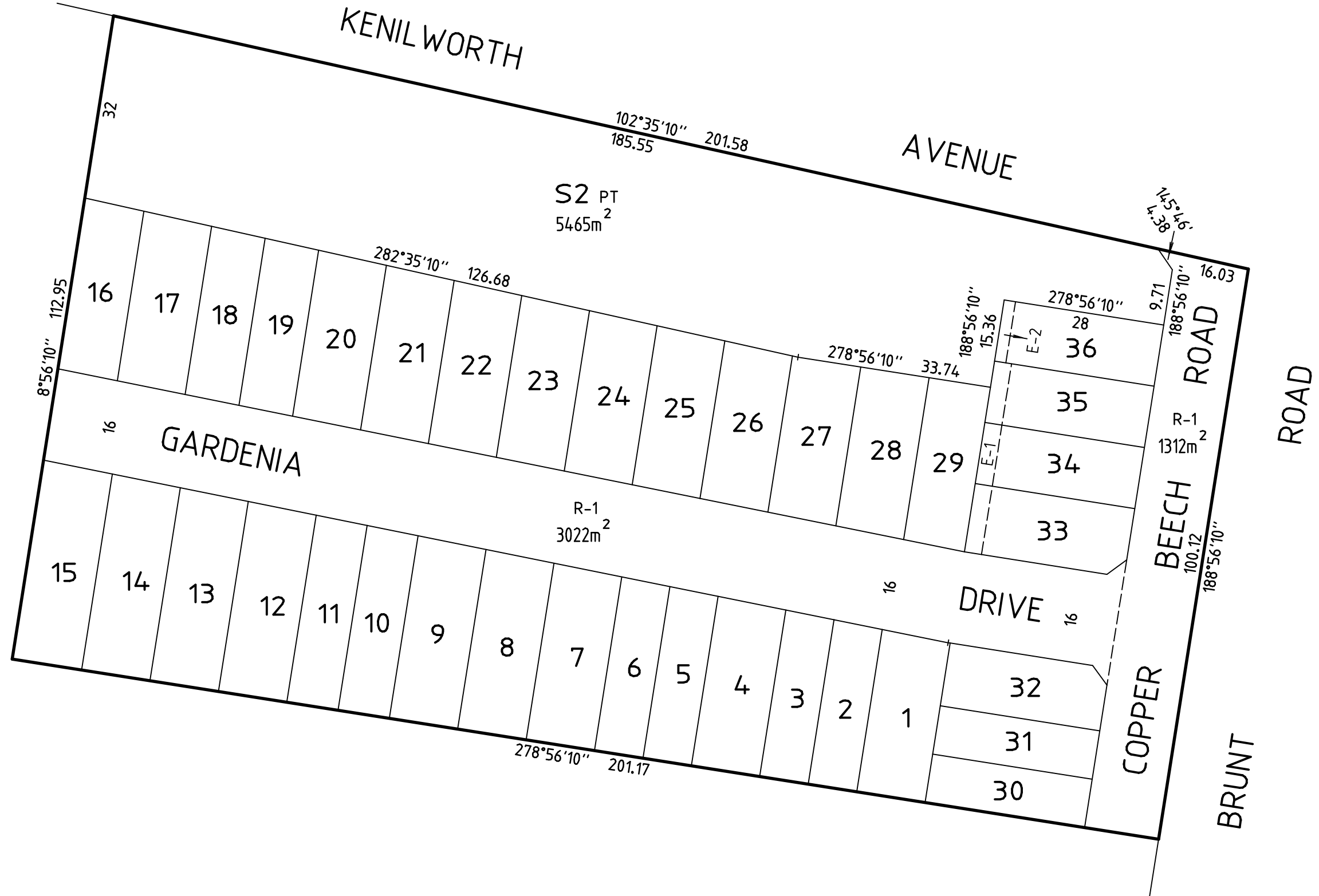

SEE SHEETS 3 & 4  
FOR LOT DIMENSIONS

**RODNEY AUJARD & ASSOCIATES**  
*Licensed Land Surveyors*

Level 1, 325 Camberwell Road, CAMBERWELL. 3124.  
Ph. 9813 2222 Fax. 9813 2244  
aujard@bigpond.net.au  
Surveyors Ref. 17965

Scale 1:750  
7.5 0 7.5 15 22.5 30 37.5  
Lengths are in metres

Original Sheet  
Size : A3

SHEET 2

Digitally signed by: Geoff Peter Sutherland (Rodney Aujard and Associates),  
Surveyor's Plan Version (10),  
24/01/2017

Digitally signed by:  
Cardinia Shire Council,  
03/03/2017,  
SPEAR Ref: S082978B

KENILWORTH AVENUE

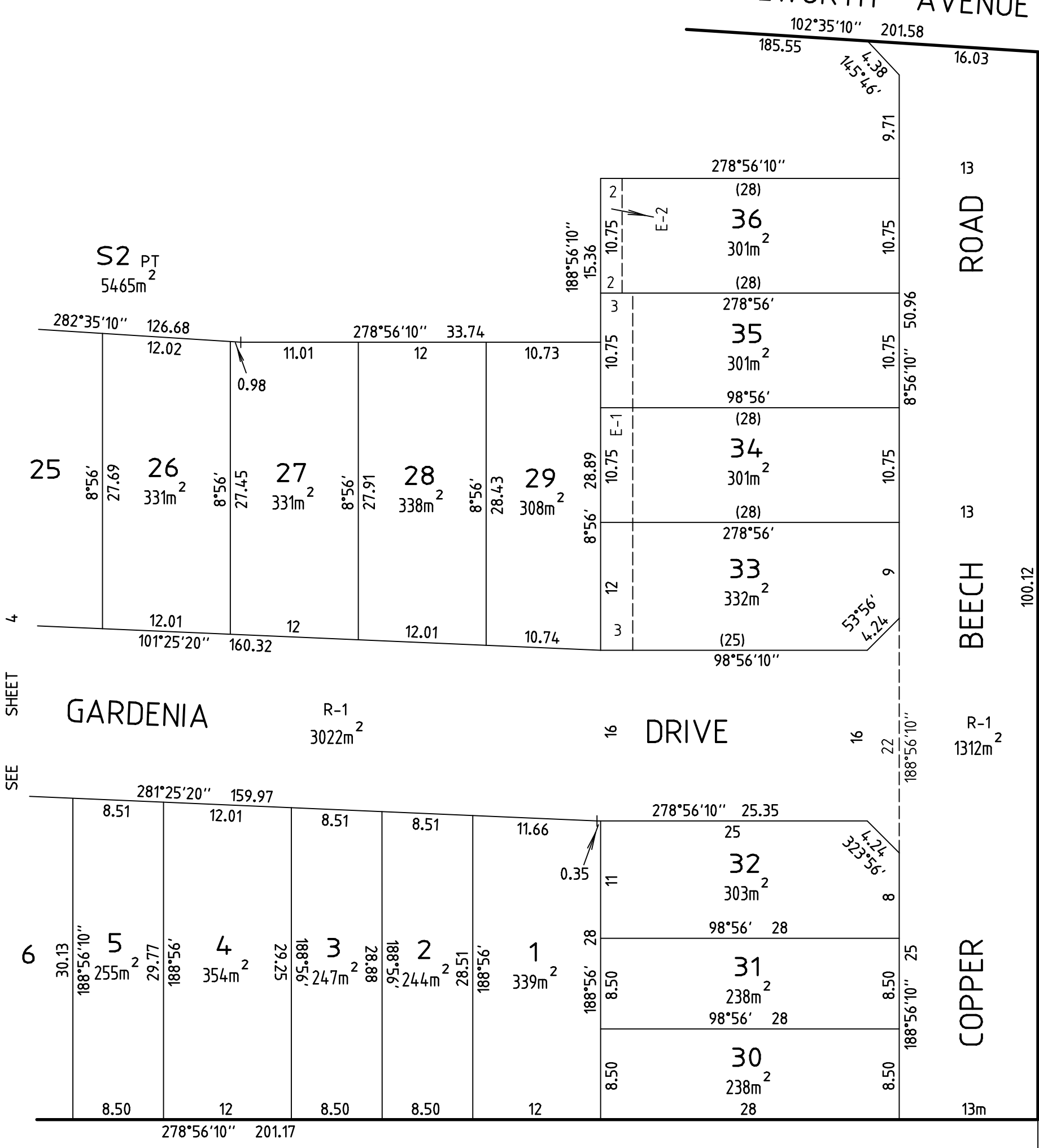

**RODNEY AUJARD & ASSOCIATES**  
Licensed Land Surveyors

Level 1, 325 Camberwell Road, CAMBERWELL. 3124.  
Ph. 9813 2222 Fax. 9813 2244

aujard@bigpond.net.au  
Surveyors Ref. 17965

Scale  
**1:400**

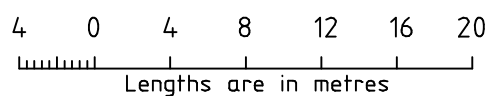

Digitally signed by: Geoff Peter Sutherland (Rodney Aujard and Associates),  
Surveyor's Plan Version (10),  
24/01/2017

Original Sheet  
Size : A3

SHEET 3

Digitally signed by:  
Cardinia Shire Council,  
03/03/2017,  
SPEAR Ref: S082978B

M.G.A. - 96  
 ZONE 55

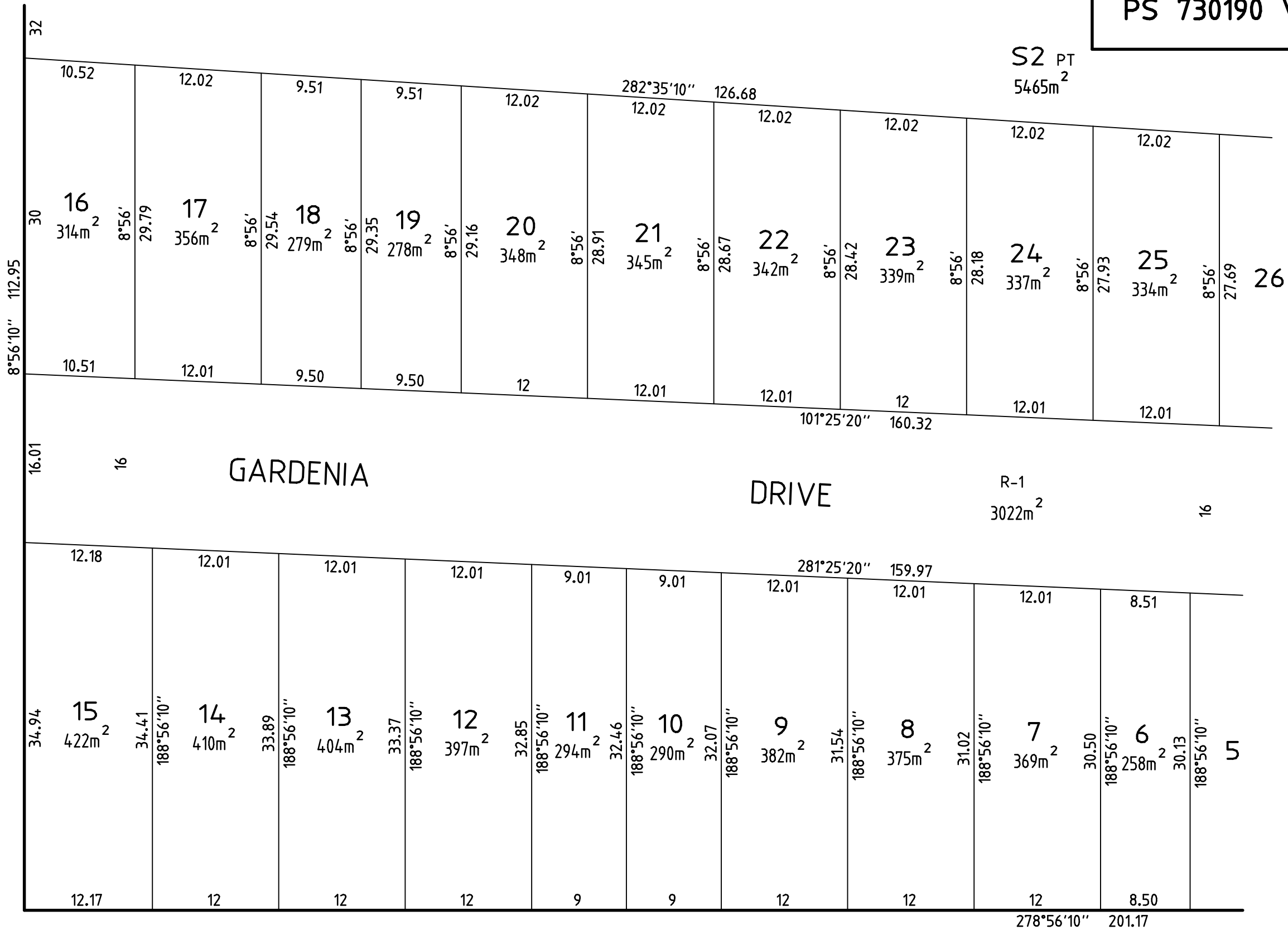

SEE SHEET 3

**RODNEY AUJARD & ASSOCIATES**  
 Licensed Land Surveyors

Level 1, 325 Camberwell Road, CAMBERWELL. 3124.  
 Ph. 9813 2222 Fax. 9813 2244  
 aujard@bigpond.net.au  
 Surveyors Ref. 17965

Scale  
**1:400**

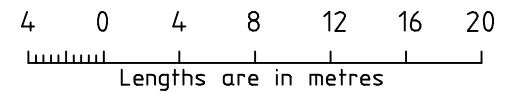

Original Sheet  
 Size : A3

SHEET 4

Digitally signed by: Geoff Peter Sutherland (Rodney Aujard and Associates),  
 Surveyor's Plan Version (10),  
 24/01/2017

Digitally signed by:  
 Cardinia Shire Council,  
 03/03/2017,  
 SPEAR Ref: S082978B

**CREATION OF RESTRICTIONS**

UPON REGISTRATION OF THIS PLAN THE FOLLOWING RESTRICTIONS ARE TO BE CREATED

LAND TO BENEFIT : LOTS ON THIS PLAN.

1. LAND TO BE BURDENED : LOTS 1, 4, 7, 8, 9, 12 to 17, 20 to 29 & 32 to 36 ON THIS PLAN

DESCRIPTION OF RESTRICTION :

THE REGISTERED PROPRIETOR OR PROPRIETORS FOR THE TIME BEING OF LOTS 1, 4, 7, 8, 9, 12 to 29 & 32 to 36 ON THIS PLAN SHALL NOT :

- (i) BUILD OR ALLOW TO BE BUILT ON THE LAND, ANY DWELLING OUTSIDE THE BUILDING ENVELOPE AS SHOWN IN THE SCHEDULE BELOW.
- (ii) BUILD OR ALLOW TO BE BUILT ANY DWELLING OTHER THAN IN ACCORDANCE WITH THE ENDORSED BUILDING DESIGN GUIDELINES ATTACHED TO PLANNING PERMIT T 130340, ISSUED BY CARDINIA SHIRE COUNCIL, OR AS AUTHORISED BY A FURTHER PERMIT.

2. LAND TO BE BURDENED : LOTS 2, 3, 5, 6, 10, 11, 18, 19, 30 & 31 ON THIS PLAN.

DESCRIPTION OF RESTRICTION :

THE REGISTERED PROPRIETOR OR PROPRIETORS FOR THE TIME BEING OF LOTS 2, 3, 5, 6, 10, 11, 18, 19, 30 & 31 ON THIS PLAN SHALL NOT :

- (i) BUILD OR ALLOW TO BE BUILT ON THE LAND, ANY DWELLING OTHER THAN IN ACCORDANCE WITH THE OFFICER SMALL LOT HOUSING CODE.
- (ii) BUILD OR ALLOW TO BE BUILT ANY DWELLING OUTSIDE THE BUILDING ENVELOPE AS DEFINED BY THE OFFICER SMALL LOT HOUSING CODE.

THIS RESTRICTION WILL EXPIRE 2 YEARS AFTER THE ISSUE OF AN OCCUPANCY PERMIT FOR THE DWELLING ON THE RESPECTIVE LOT.

**SCHEDULE**

See Sheet 6

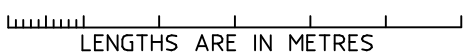
<b>RODNEY AUJARD &amp; ASSOCIATES</b> <i>Licensed Land Surveyors</i> Level 1, 325 Camberwell Road, CAMBERWELL. 3124. Ph. 9813 2222 Fax. 9813 2244 aujard@bigpond.net.au SURVEYORS FILE REF : 17965	SCALE	 LENGTHS ARE IN METRES	ORIGINAL SHEET SIZE : A3	SHEET 5
	Digitally signed by: Geoff Peter Sutherland (Rodney Aujard and Associates), Surveyor's Plan Version (10), 24/01/2017	Digitally signed by: Cardinia Shire Council, 03/03/2017, SPEAR Ref: S082978B		

SCHEDULE

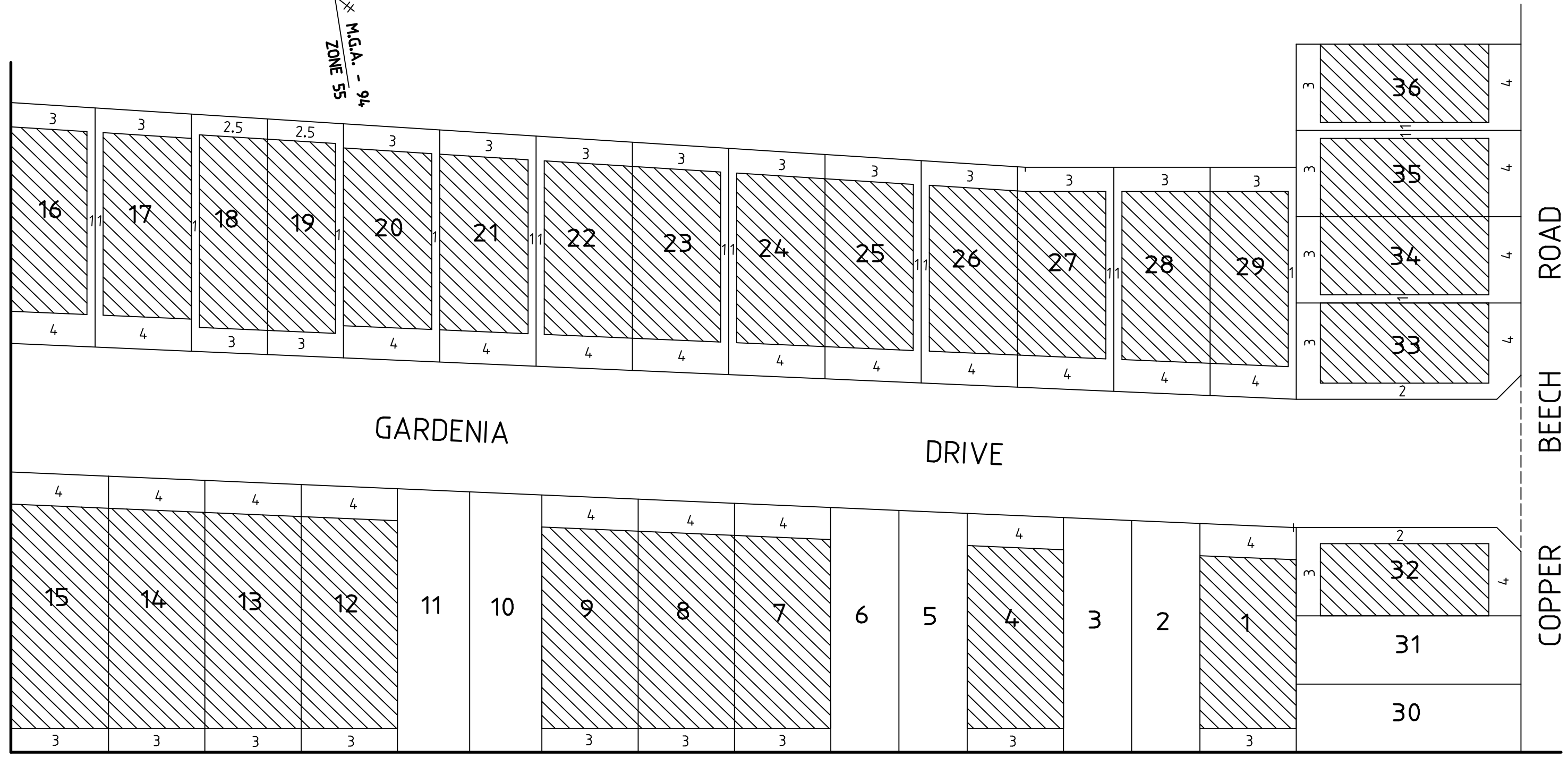
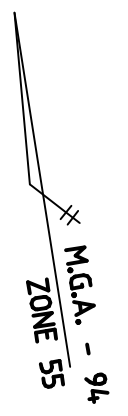

 Building Envelope

**RODNEY AUJARD & ASSOCIATES**  
*Licensed Land Surveyors*  
 Level 1, 325 Camberwell Road, CAMBERWELL. 3124.  
 Ph. 9813 2222 Fax. 9813 2244  
 aujard@bigpond.net.au  
 Surveyors Ref. 17965

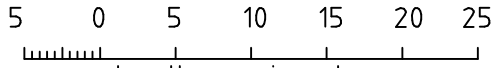
Scale **1:500**  
  
 Lengths are in metres

Original Sheet Size : A3  
 SHEET 6

Digitally signed by: Geoff Peter Sutherland (Rodney Aujard and Associates),  
 Surveyor's Plan Version (10),  
 24/01/2017

Digitally signed by:  
 Cardinia Shire Council,  
 03/03/2017,  
 SPEAR Ref: S082978B